

# SURGiNG

紹 鑫 實 業

SURGiNG | 电源浪涌保护器



# Surge protection Device

## 浪涌保护器

TM10P277 Series



**Description**

TM10P277 is an on-board power supply lightning protection module; it is used for surge protection of commercial lighting, communication base stations, security, electrical appliances, sockets and other power ports. The lightning protection device adopts full mode protection, adopts UVT<sup>1</sup> technology, and has leakage current<sup>2</sup> and freewheeling<sup>3</sup> interruption function. The product is small in size and can be soldered on a PCB circuit board for easy installation and application. The product's maximum discharge current is 10kA<sup>4</sup> and the nominal discharge current is 5kA<sup>5</sup>.

**Applications**

- I Commercial lighting
- I Security power supply
- I Communication power supply
- I Industrial power supply
- I Precision machine tools
- I Machine room plug
- I Single phase motor
- I New energy source supply
- I Solar powered
- I 5G base station

Note:

1. UVT: It is an abbreviation of Ultra low voltage triggering technology. It is a design that absorb the high and low voltage energy of the surge in advance. It can absorb the surge energy more completely, and the residual voltage is low, and the protection effect on the back-end equipment is obvious. This technology is patented by SURGiNG
2. Leakage current: In this paper, the current flowing through the SPD does not occur when the power is connected. For example, zinc oxide varistor is a device with leakage characteristics.
3. Freewheeling: Current from the connected power source that flows through the SPD during and after the discharge current passes. For example, gas discharge tubes and thyristors are devices with freewheeling characteristics (cited from IEC61643-11).
4. 10kA: Refers to the maximum discharge current (Imax) in the 8/20μs surge waveform test.
5. 5kA: Refers to the nominal discharge current (In) during 8/20 μ s surge waveform test

Specification	Test Standard: EN61643-11/ UL1449 <sup>4th</sup>	TM10P277	Units
<b>Electrical parameters</b>			
Rated operating voltage <sup>6</sup>		277	VAC
Max AC Voltage Range <sup>7</sup>		277	VAC
Cross-section area (Flexible)		18	mm <sup>2</sup> /AWG
Mounting on		Custom	
<b>Surge parameter</b>			
Norminal discharge current (8/20μs) <sup>8</sup> (In)		5	kA
Max. discharge current (8/20μs) <sup>9</sup> (Imax)		10	kA
Voltage protection level <sup>10</sup> (Up)			
	L-N	950	V
	L-PE	950	V
	N-PE	1600	V

Placement and transportation parameters		
Enclosure material	ABS765A(94V0)	
Operating ambient temperature range	-40~80	°C
Storage temperature range	-40~+125	°C
Size	31.4×20.4×18.2	mm
Weight (One piece)	25(±3)	g
Package size	395×267×285	mm
Package quantity	210	pcs

Note:

- Rated operating voltage: The normal AC mains voltage rating assigned by the manufacturer to the SPD (cited from UL1449<sup>4th</sup>)
- Max ac voltage range: The maximum AC voltage RMS that can be continuously applied to the SPD.
- Nominal discharge current: The current peak selected by the manufacturer. With SPD, the current waveform is 8/20μs, and the SPD remains functional after 15 surges (quoted from UL1449<sup>4th</sup>).
- Maximum discharge current: The peak value of the SPD current flowing through the 8/20 waveform and the manufacturer's claimed amplitude. Belongs to the T2 test type (quoted from IEC61643-11).
- Voltage protection level: The maximum voltage expected to occur between the two ends of the SPD due to the application of a specified gradient of the surge voltage and the specified amplitude and the inrush current of the waveform (cited from IEC61643-11).

**Surge test characteristics of TM10P277**

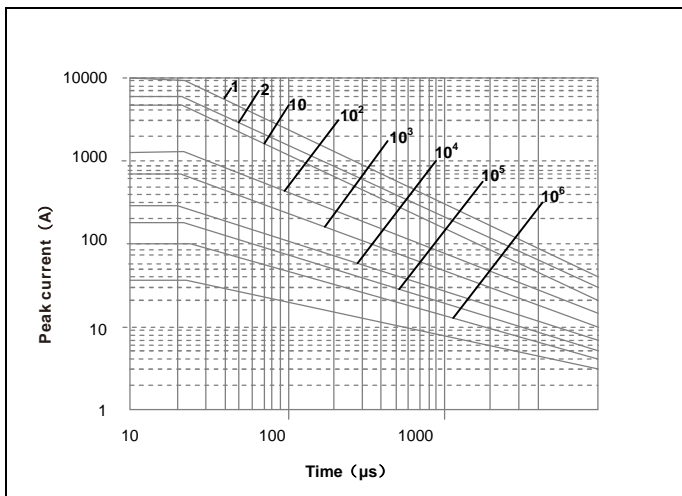

**Features**

- ▮ Nominal discharge current: 5kA, 8/20μs;
- ▮ Maximum discharge current: 10kA, 8/20μs;
- ▮ Executive standard: IEC/EN:61643-11/UL1449<sup>4th</sup>;
- ▮ Parallel SPD module;
- ▮ UVT ultra-low voltage technology, more adequate protection;
- ▮ Onboard components, soldered directly to the PCB;
- ▮ Compact shape: 31.4×20.4×18.2, easy to install;
- ▮ Meet the voltage range of 110 ~ 277VAC;
- ▮ Excellent performance after TTF's rigorous testing.

Test	Surge	Strikes
<b>Pulse Rating (8/20μs)</b>	10kA	1
	8kA	2
	5kA	15
	3.75kA	45
	2.5kA	200
<b>TTF DATE</b>	10kA	2
	5kA	50

About UVT

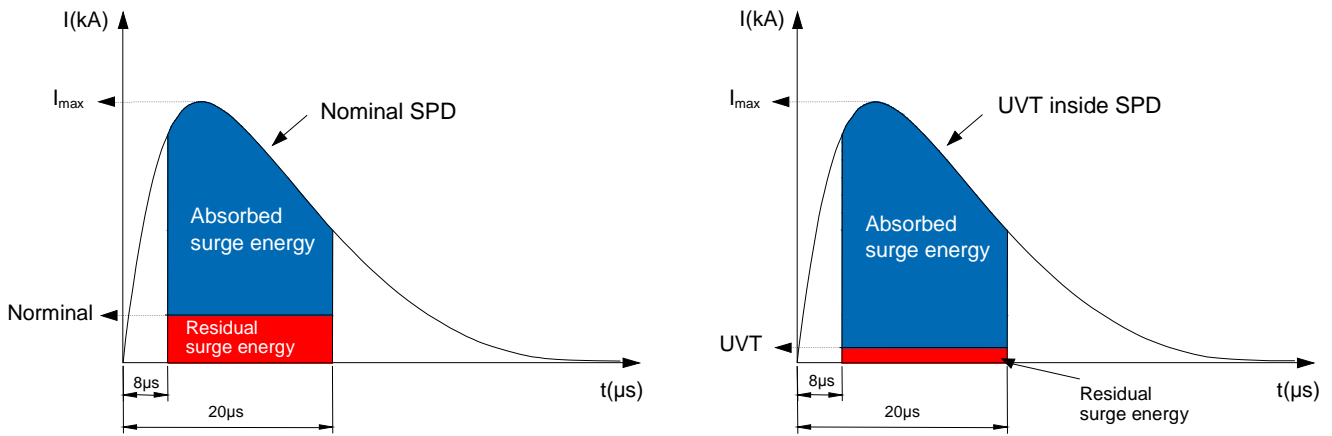

Since the introduction of the 20kV ultra-thin surge suppressor in 2014, SURGiNG Electronics has continuously improved its surge protection technology and proposed the theoretical concept of efficient absorption of surge energy. After many tests, the circuit model was established and the ultra-low voltage triggering scheme (UVT1) was introduced. It was applied to the new totem surge suppressor, which greatly improved the surge protection efficiency and played a good role in the protected equipment. Surge protection effect.

Application/ Inatallation Schematic (Unit:mm)

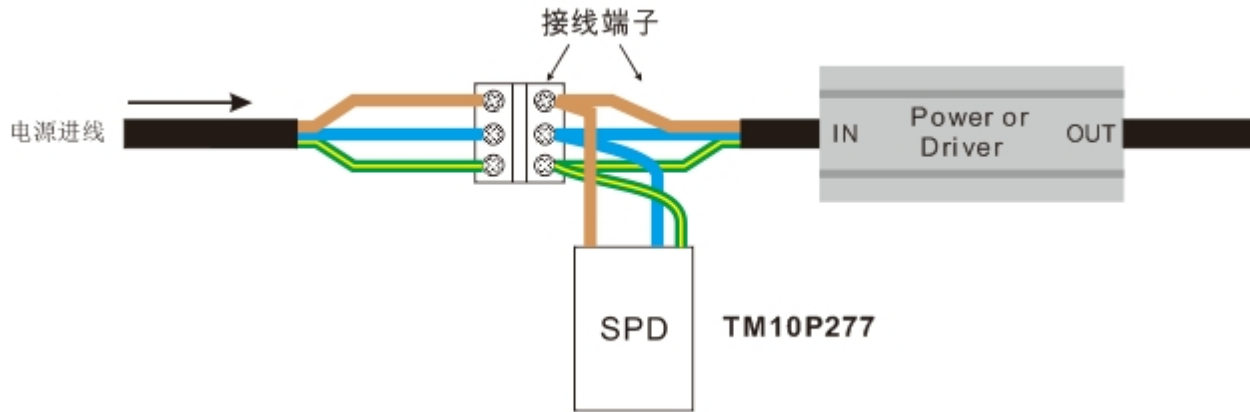

Notes:

1. The connection line of the lightning arrester will be connected after tining.
2. If there are no wiring terminals, wires should be welded, and the welds need to do isolation treatment.
3. L---Brown; N---Blue; PE---Yellow and Green.

Dimensions Typical Dimensions (mm)

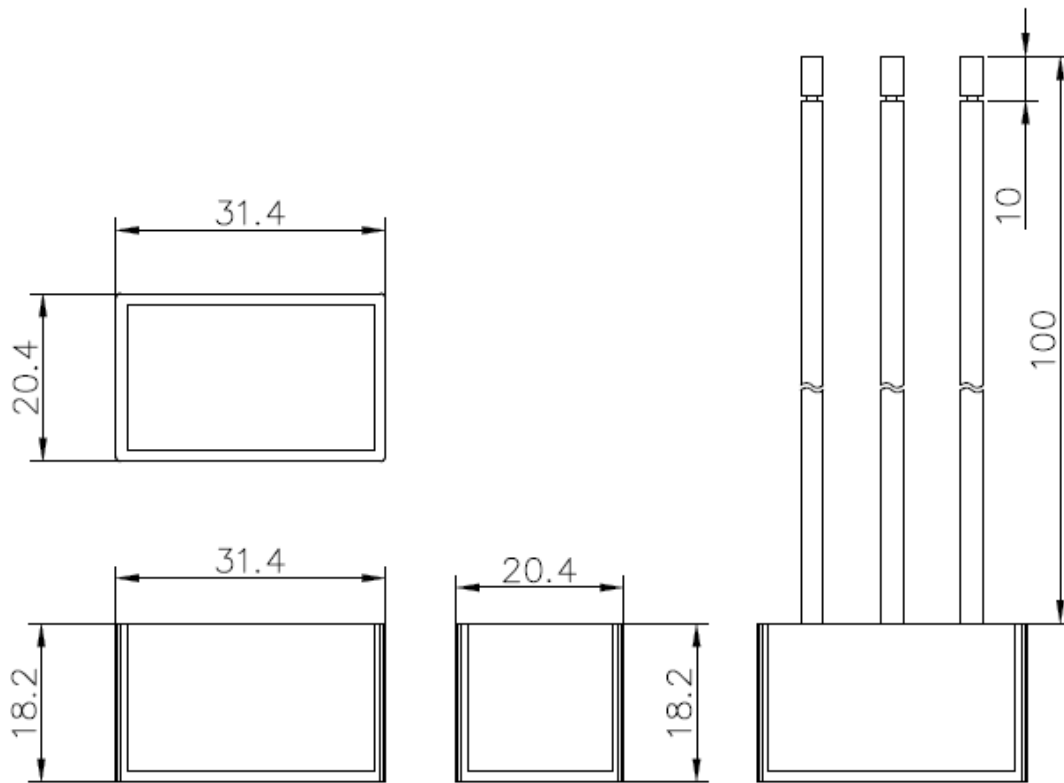

**Disclaimer Notice** - Information furnished is believed to be accurate and reliable. However, users should independently evaluate the suitability of and test each product selected for their own applications. SURGiNG products are not designed for, and may not be used in, all applications.