

Surface Mountable PTC Resettable Fuse: JK-SMD2920 Series

Features:

- ✧ RoHS Compliant & Halogen Free
- ✧ faster tripping, 2920 Dimension, Surface mountable, Solid state
- ✧ Operation Current: 0.30A~3.00A
- ✧ Maximum Voltage: 6V~60Vdc
- ✧ Operating Temperature: -40℃ TO 85℃
- ✧ Agency recognition:UL、CSA

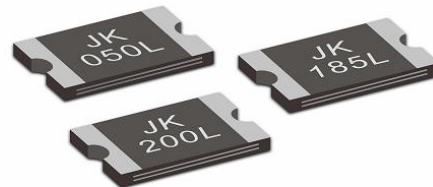

Product Dimensions

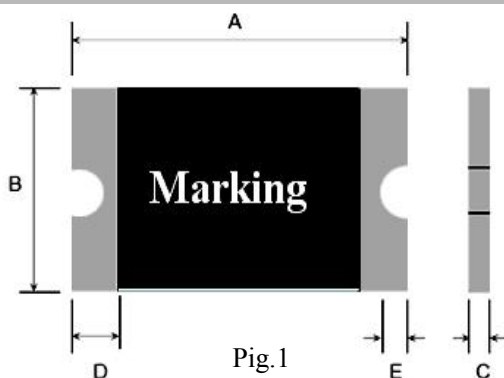

Terminal pad materials :Tin-Plated Nickle-copper
 Terminal pad solderability : Meets EIA specification
 RS 186-9E and ANSI/J-STD-002 Category 3.

Unit : mm

Model	Marking	A		B		C		D	E
		Min	Max	Min	Max	Min	Max	Min	Min
JK-SMD030L	JK030L	6.73	7.98	4.80	5.44	0.60	1.15	0.30	0.15
JK-SMD050L	JK050L	6.73	7.98	4.80	5.44	0.60	1.15	0.30	0.15
JK-SMD075L	JK075L	6.73	7.98	4.80	5.44	0.60	1.15	0.30	0.15
JK-SMD100L	JK100L	6.73	7.98	4.80	5.44	0.60	1.00	0.30	0.15
JK-SMD125L	JK125L	6.73	7.98	4.80	5.44	0.60	1.00	0.30	0.15
JK-SMD150L	JK150L	6.73	7.98	4.80	5.44	0.60	1.20	0.30	0.15
JK-SMD185L	JK185L	6.73	7.98	4.80	5.44	0.60	1.20	0.30	0.15
JK-SMD200L	JK200L	6.73	7.98	4.80	5.44	0.40	0.80	0.30	0.15
JK-SMD200L-24	JK200L	6.73	7.98	4.80	5.44	0.60	1.00	0.30	0.15
JK-SMD250L	JK250L	6.73	7.98	4.80	5.44	0.40	0.80	0.30	0.15
JK-SMD260L	JK260L	6.73	7.98	4.80	5.44	0.40	0.80	0.30	0.15
JK-SMD300L-6	JK300L	6.73	7.98	4.80	5.44	0.40	0.80	0.30	0.15
JK-SMD300L-16	JK300L	6.73	7.98	4.80	5.44	0.60	1.20	0.30	0.15



Thermal Derating Chart-IH (A)

Model	Maximum ambient operating temperatures (°C)								
	-40	-20	0	25	40	50	60	70	85
JK-SMD030L	0.44	0.37	0.35	0.30	0.28	0.23	0.20	0.18	0.14
JK-SMD050L	0.73	0.62	0.59	0.50	0.47	0.38	0.34	0.30	0.24
JK-SMD075L	1.09	0.92	0.88	0.75	0.70	0.56	0.50	0.45	0.36
JK-SMD100L	1.45	1.23	1.17	1.00	0.93	0.75	0.67	0.60	0.48
JK-SMD125L	1.81	1.54	1.46	1.25	1.16	0.94	0.84	0.75	0.60
JK-SMD150L	2.18	1.85	1.76	1.50	1.40	1.13	1.01	0.90	0.72
JK-SMD185L	2.68	2.28	2.16	1.85	1.72	1.39	1.24	1.11	0.89
JK-SMD200L	2.90	2.46	2.34	2.00	1.86	1.50	1.34	1.20	0.96
JK-SMD200L-24	2.90	2.46	2.34	2.00	1.86	1.50	1.34	1.20	0.96
JK-SMD250L	3.63	3.08	2.93	2.50	2.33	1.88	1.68	1.50	1.20
JK-SMD260L	3.77	3.20	3.04	2.60	2.42	1.95	1.74	1.56	1.25
JK-SMD300L-6	4.35	3.69	3.51	3.00	2.79	2.25	2.01	1.80	1.44
JK-SMD300L-16	4.35	3.69	3.51	3.00	2.79	2.25	2.01	1.80	1.44

Electrical Characteristic

Model	V _{max}	I _{max}	I _{hold}	I _{trip}	P _d	Maximum time to trip		Resistance	
	(Vdc)	(A)	(A)	(A)	Max. (W)	Current	Time	R _{i_min}	R _{l_max}
						(A)	(Sec)	(Ω)	(Ω)
SMD030L	60	100	0.30	0.60	1.5	1.5	3.0	0.60	4.80
SMD050L	60	100	0.50	1.00	1.5	2.5	4.0	0.18	1.40
SMD075L	33	100	0.75	1.50	1.5	8.0	0.3	0.10	1.00
SMD100L	33	100	1.00	2.20	1.5	8.0	0.5	0.065	0.41
SMD125L	33	100	1.25	2.50	1.5	8.0	2.0	0.05	0.25
SMD150L	33	100	1.50	3.00	1.5	8.0	2.0	0.035	0.23
SMD185L	33	100	1.85	3.70	1.5	8.0	2.5	0.030	0.15
SMD200L	16	100	2.00	4.00	1.5	8.0	4.5	0.020	0.12
SMD200L-24	24	100	2.00	4.00	1.5	8.0	4.5	0.020	0.12
SMD250L	16	100	2.50	5.00	1.5	8.0	16.0	0.020	0.085
SMD260L	16	100	2.60	5.20	1.5	8.0	10.0	0.014	0.075
SMD300L-6	6	100	3.00	6.00	1.5	8.0	20.0	0.012	0.048
SMD300L-16	16	100	3.00	6.00	1.5	8.0	20.0	0.012	0.050



Modeling System

JK- SMD - □□□ L

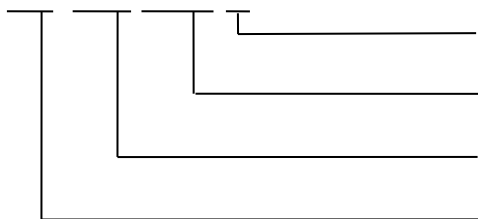

- 2920 Dimension
- Holding current Rating
- Surface Mount Device
- JK mark

Test Procedures And Requirements

Test	Test Conditions	Accept/Reject Criteria
Resistance	In still air @ 25 °C	$R_{min} \leq R \leq R_{max}$
Time to Trip	Specified current, V_{max} , 25 °C	Tmaximum Time to Trip
Hold Current	30min, at I_H	No trip
Trip Cycle Life	V_{max} , I_{max} , 100cycles	No arcing or burning
Trip Endurance	V_{max} , 1 hours	No arcing or burning

Physical Characteristics and Environmental Specifications

Physical Characteristics

Terminal materials :	Tin-Plated Nickle-copper
Soldering zone	Meets EIA specification RS 186-9E and ANSI/J-STD-002 Category 3.

Environmental Specifications

Test	Conditions	Resistance Change
Passive aging	85 °C ,1000hours	±10%
Humidity aging	85 °C /85%RH.1000 hours	±5%
Thermal shock	MIL-STD-202,Method 107G+85 °C /-40 °C ,20times	-30% typical resistance change
Solvent Resistance	MIL-STD-202,Method 215	no change
Vibration	ML-STD-883C,Test Condition A	No chage



Electrical Specifications:

I_{hold} = Hold Current. Maximum current device will not trip in 25°C still air.

I_{trip} = Trip Current. Minimum current at which the device will always trip in 25°C still air.

V_{max} = Maximum operating voltage device can withstand without damage at rated current (I_{max}).

I_{max} = Maximum fault current device can withstand without damage at rated voltage (V_{max}).

P_d = Maximum power dissipation when device is in the tripped state in 25°C still air environment at rated voltage.

$R_{i_{min/max}}$ = Minimum/Maximum device resistance prior to tripping at 25°C.

$R_{l_{max}}$ = Maximum device resistance is measured one hour post reflow.

Recommended pad layout (mm)

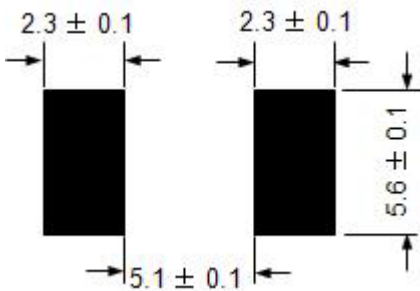

Solder reflow conditions

Profile Feature	Pb-Free Assembly
Average ramp up rate ($T_{S_{MAX}}$ to T_p)	3°C/second max.
Preheat	
• Temperature min. ($T_{S_{MIN}}$)	150°C
• Temperature max. ($T_{S_{MAX}}$)	200°C
• Time ($t_{S_{MIN}}$ to $t_{S_{MAX}}$)	60-120 seconds
Time maintained above:	
• Temperature (T_L)	217°C
• Time (t_L)	60-150 seconds
Peak/Classification temperature (T_p)	260°C
Time within 5°C of actual peak temperature	
Time (t_p)	30 seconds max.
Ramp down rate	3°C/second max.
Time 25°C to peak temperature	8 minutes max.

Note: All temperatures refer to topside of the package, measured on the package body surface.

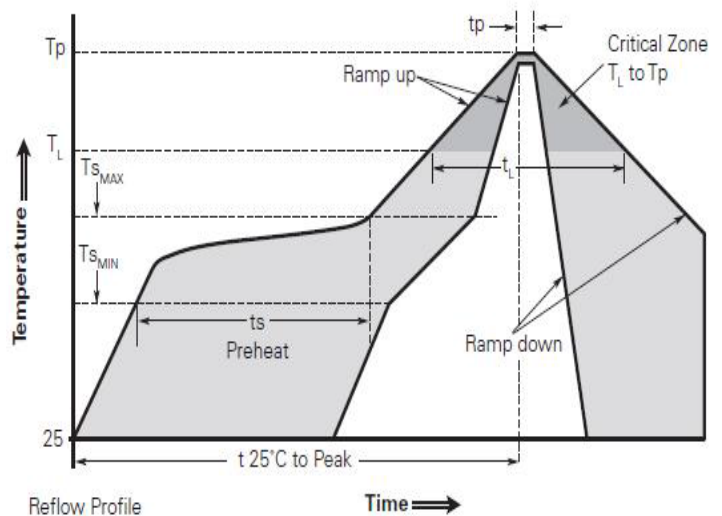

- Recommended reflow methods: IR, vapor phase oven, hot air oven, N₂ environment for lead-free.
- Devices are not designed to be wave soldered to the bottom side of the board.
- Recommended maximum paste thickness is 0.25mm (0.010inch).
- Devices can be cleaned using standard industry methods and solvents.



- Soldering temperature profile meets RoHs leadfree process.

Notes: If reflow temperatures exceed the recommended profile, devices may not meet the performance requirements

Tape Specification And Reel Dimensions

Covering Specifications EIA 481-1(Unit:mm)	
W	16± 0.3
P ₀	4.0 ± 0.10
P ₁	8.0 ± 0.10
P ₂	2.0 ± 0.10
A ₀	5.74 ± 0.10
B ₀	8.02 ± 0.10
D ₀	1.55 ± 0.05
F	7.5± 0.10
E ₁	1.75 ± 0.10
T	0.20± 0.10
Leader min.	390
Trailer min.	160
Reel Dimensions	
A	178± 1
N	58± 1
W ₁	16.9± 0.80
W ₂	19.3± 0.1

EIA Tape Component Dimentions

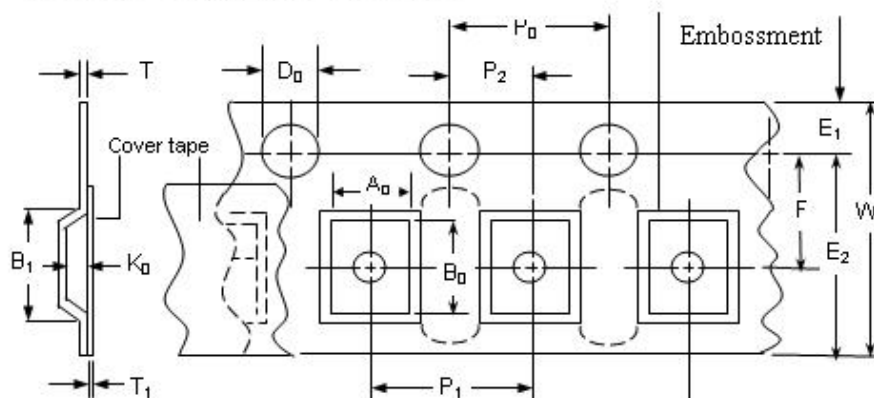

EIA Reel Dimentions

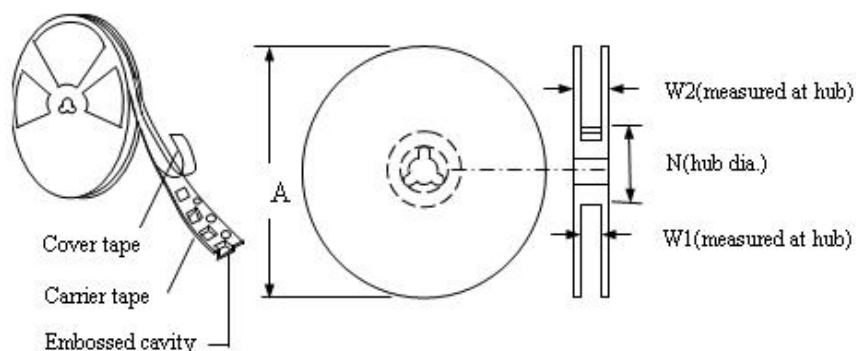

Packaging Quantity

Model	Quantity	Model	Quantity
SMD030L	2000	SMD200L	2000
SMD050L	2000	SMD200L-24	1500
SMD075L	2000	SMD250L	2000
SMD100L	2000	SMD260L	2000
SMD125L	2000	SMD300L	1500
SMD150L	2000	SMD300L-6	2000
SMD185L	1500		



Storage

The maximum ambient temperature shall not exceed 38°C. Storage temperatures higher than 38°C could result in the deformation of packaging materials. The maximum relative humidity recommended for storage is 60%. High humidity with high temperature can accelerate the oxidation of the solder plating on the termination and reduce the solderability of the components. Sealed plastic bags with desiccant shall be used to reduce the oxidation of the termination and shall only be opened prior to use. The products shall not be stored in areas where harmful gases containing sulfur or chlorine are present

